

Rev No	Revision note	Date	Drawn	Checked

CONFIDENTIAL
All rights reserved.
Reproduction of this
drawing to third
parties is prohibited.

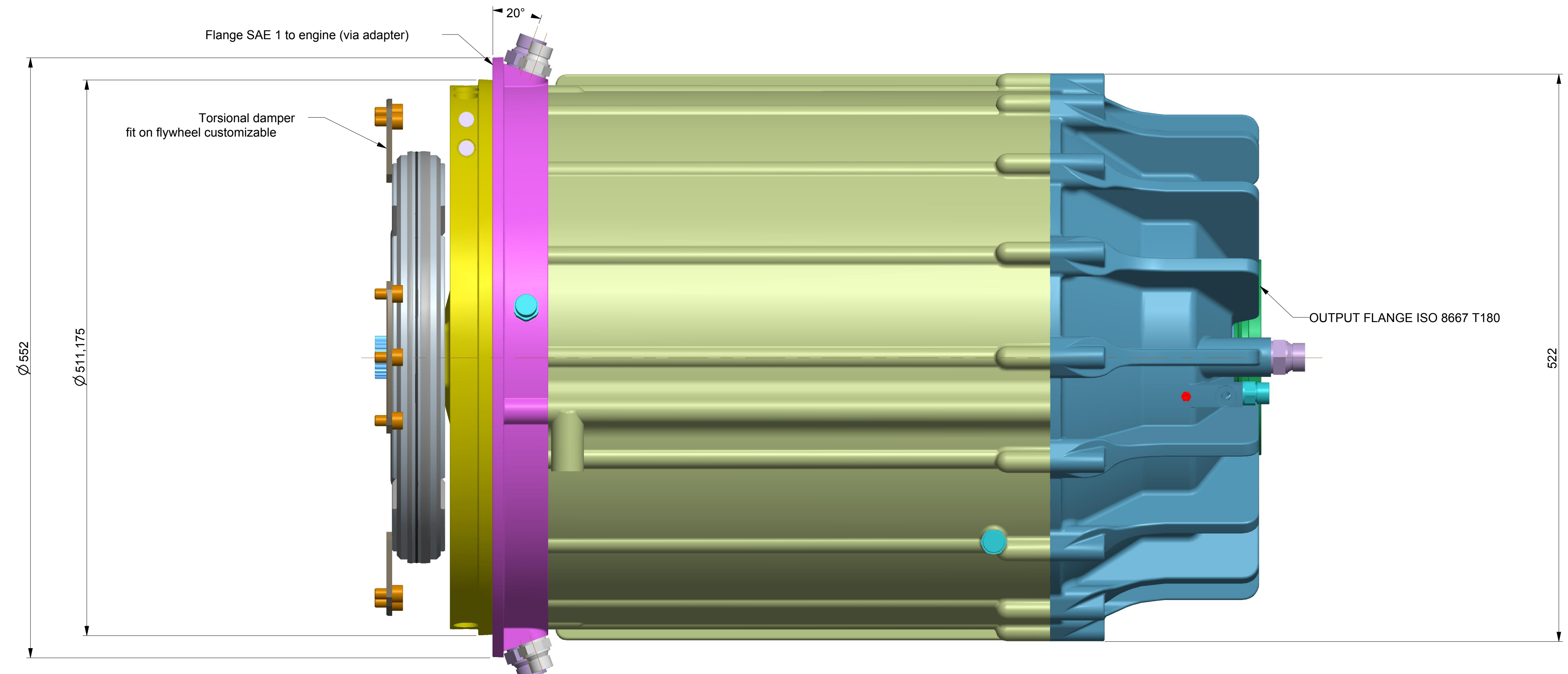
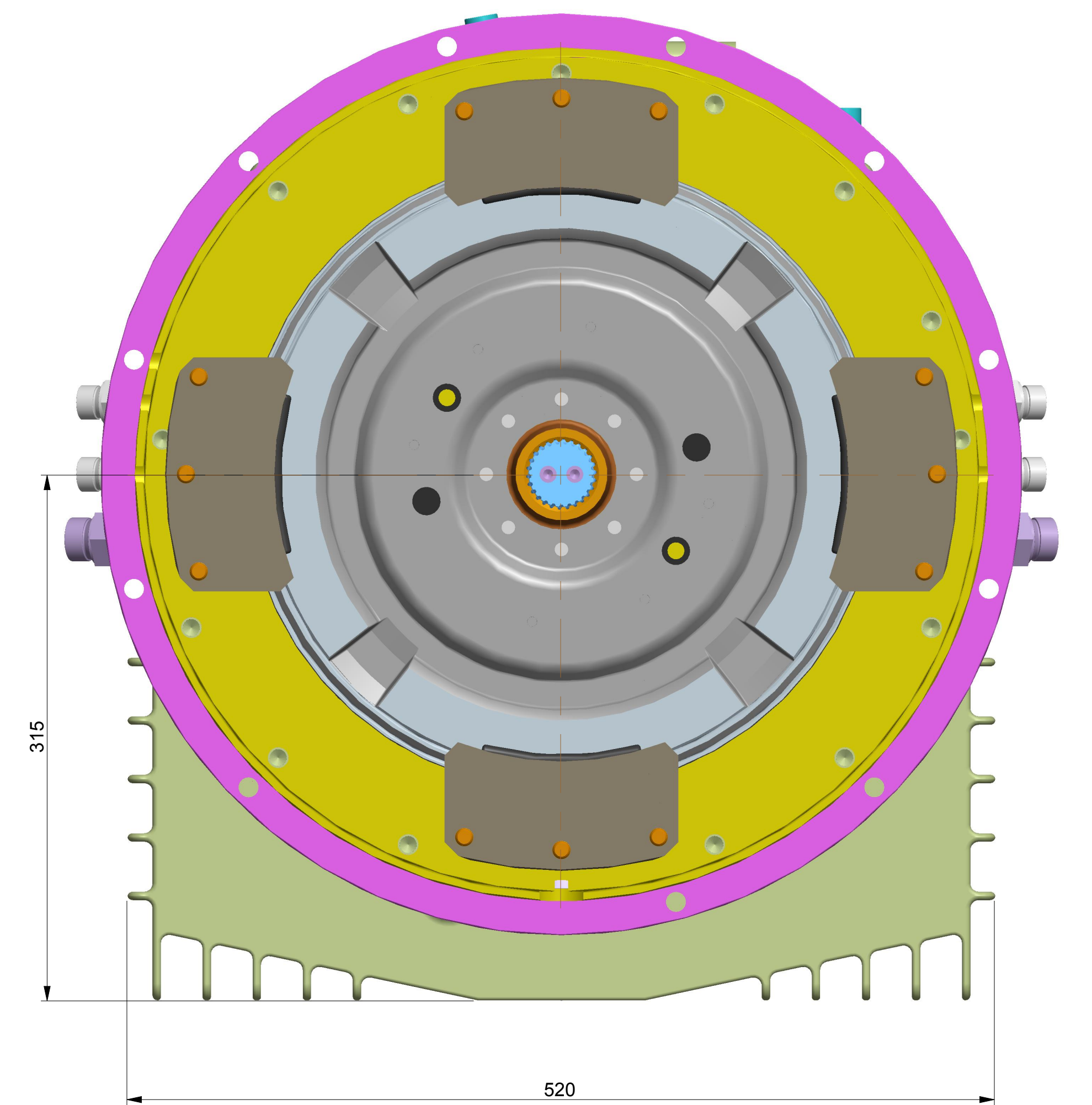
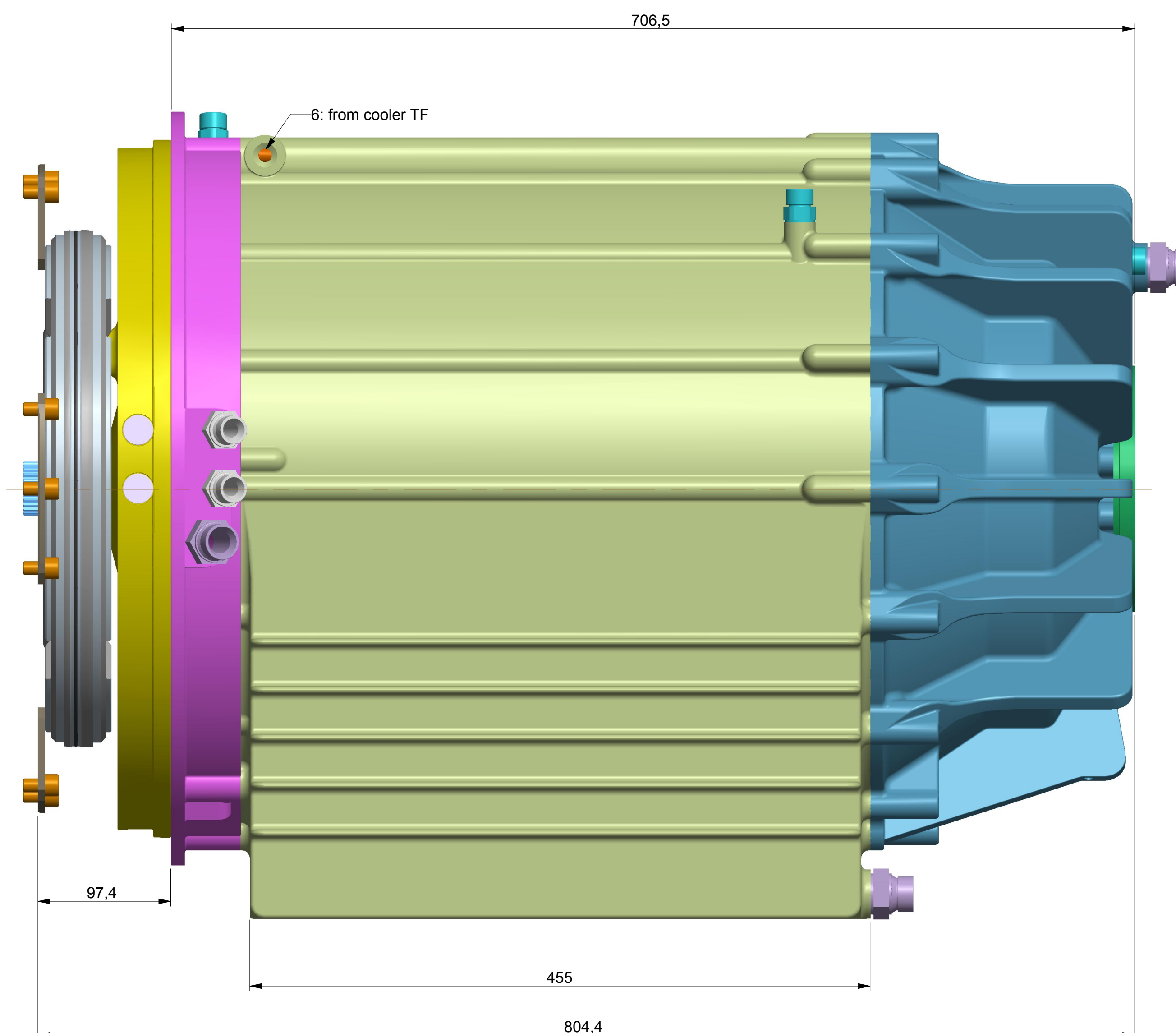
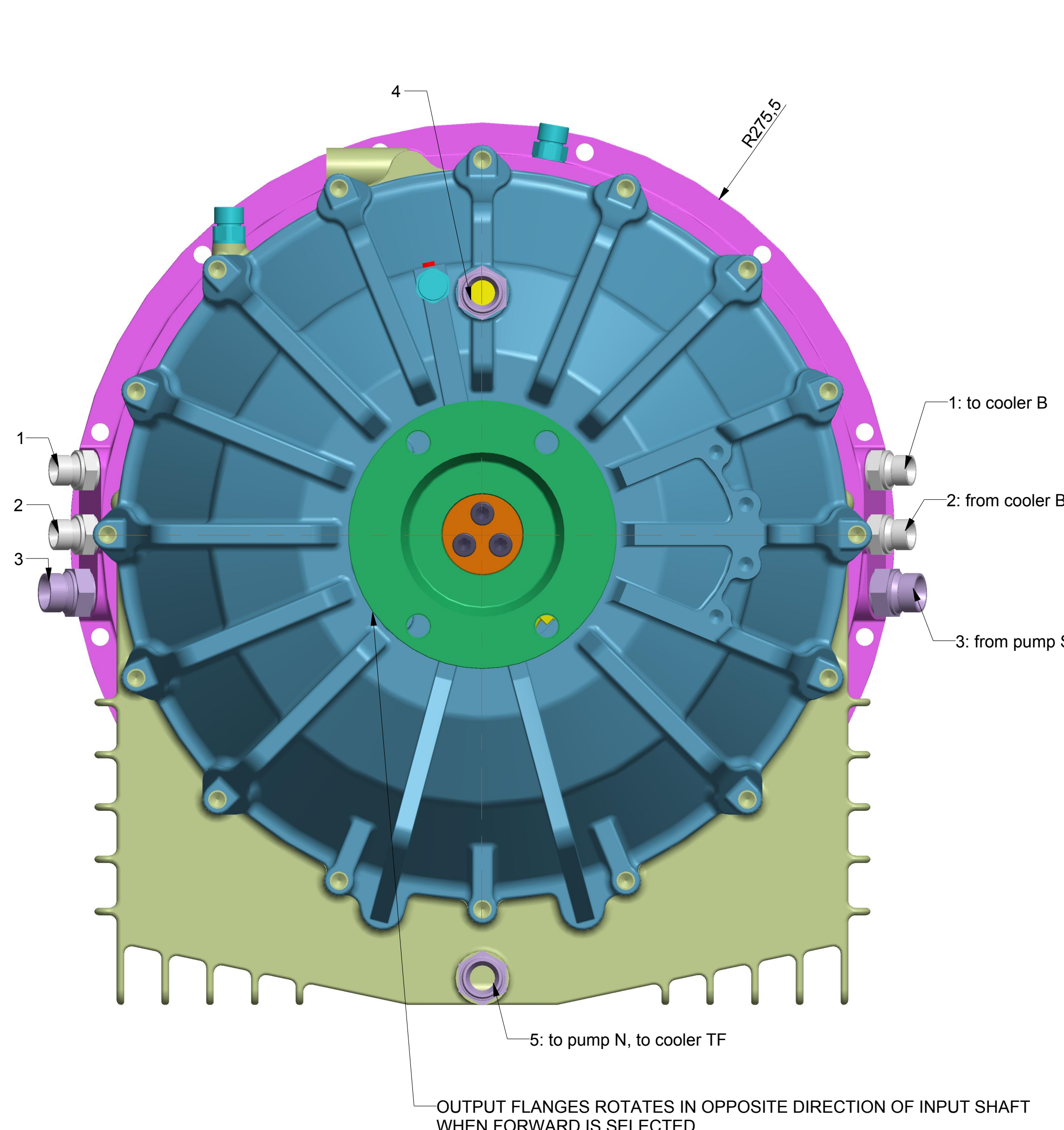

Port	HYDRAULIC CONNECTIONS
1	To cooler B
2	From cooler B
3	From Pump S
4	From pump N
5	To pump N, to cooler TF
6	From cooler TF

TOLERANCING	GENERAL TOLERANCES
ISO 8015	UNLESS SPECIFIED PER ISO 2001:2001
SURFACE FINISH	UNLESS SPECIFIED
ISO 13715	UNLESS SPECIFIED
ISO 13715	UNLESS SPECIFIED
ISO 13715	UNLESS SPECIFIED
ISO 13715	UNLESS SPECIFIED
ISO 13715	UNLESS SPECIFIED
ISO 13715	UNLESS SPECIFIED
ISO 13715	UNLESS SPECIFIED
ISO 13715	UNLESS SPECIFIED

Material	Heat treatment	Hardness	Weight
Designed by	Checked by	Approved by, date	Filename RVT 310
Scale 1:2.5		Size AO	DIMENSIONS ARE IN MM
Version		Sheet	

MAZARO RVT310 INSTALLATION